

zulässiger Mittenversatz in Längs und Querrichtung jeweils $\pm 0,7\text{mm}$
Allowed misalignment in longitudinal and transverse axes $\pm 0,7\text{mm}$

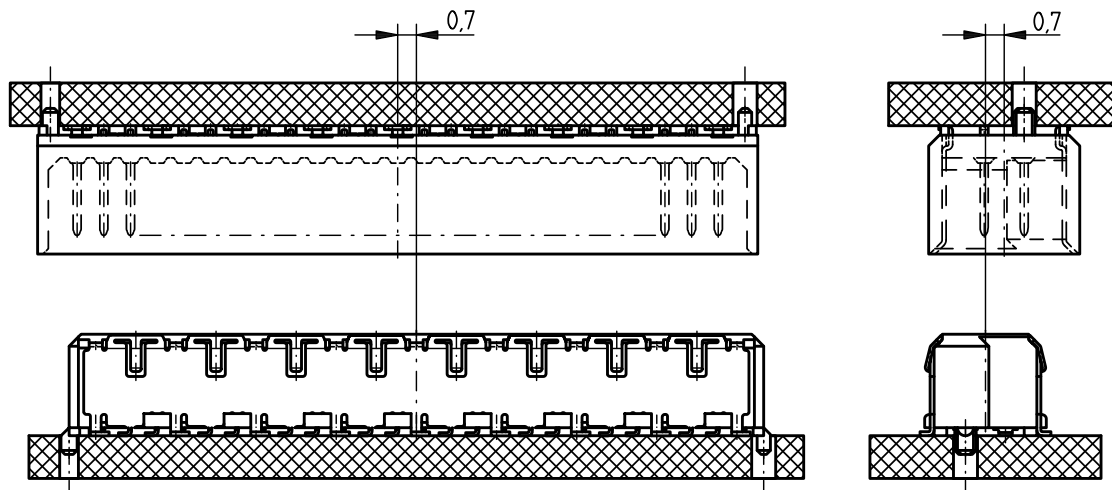

zulässiger Winkelversatz längs: $\pm 2^\circ$, quer: $\pm 2^\circ$
Allowed angular inclination longitudinal: $\pm 2^\circ$, transverse: $\pm 2^\circ$

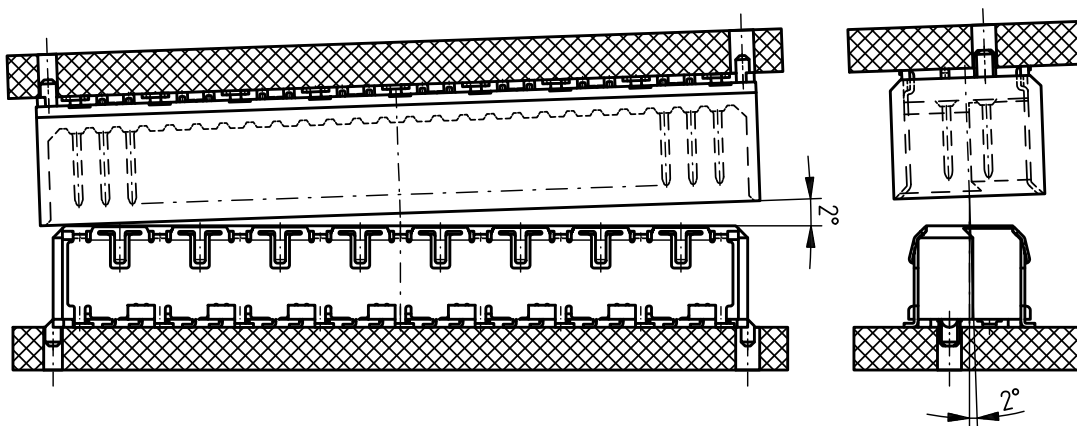

"Board to Board" Abstand für sichere Kontaktgabe: 5,0-6,5mm
"Board to Board" distance for secure mating: 5,0-6,5mm

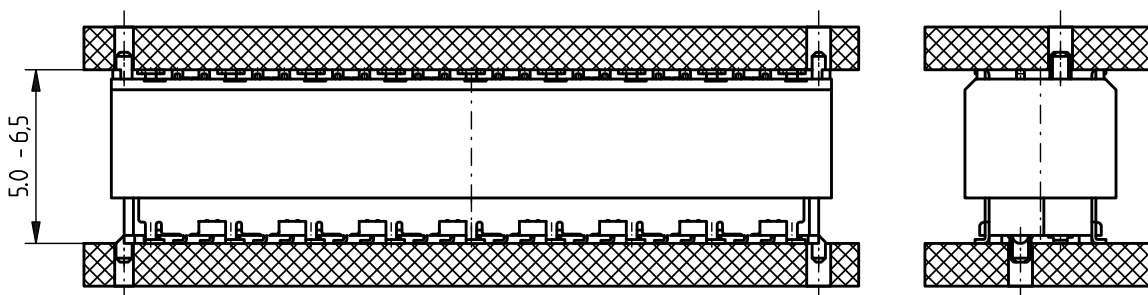

Information: All rights reserved. Only for information. To insure that this is the latest version of this drawing, please contact one of the ERNI companies before using.	Tolerances  All Dimensions in mm	Scale 5:1
	Subject to modification without prior notice. Drawing will not be updated.	Designation Steckbedingungen, MicroSpeed <i>Mating conditions, MicroSpeed</i>
ERNI www.ERNI.com	E03376 MSPEED	
Index	Date	V:00037147.SZA