

AdvancedTCA Connectors

acc. to PICMG 3.0

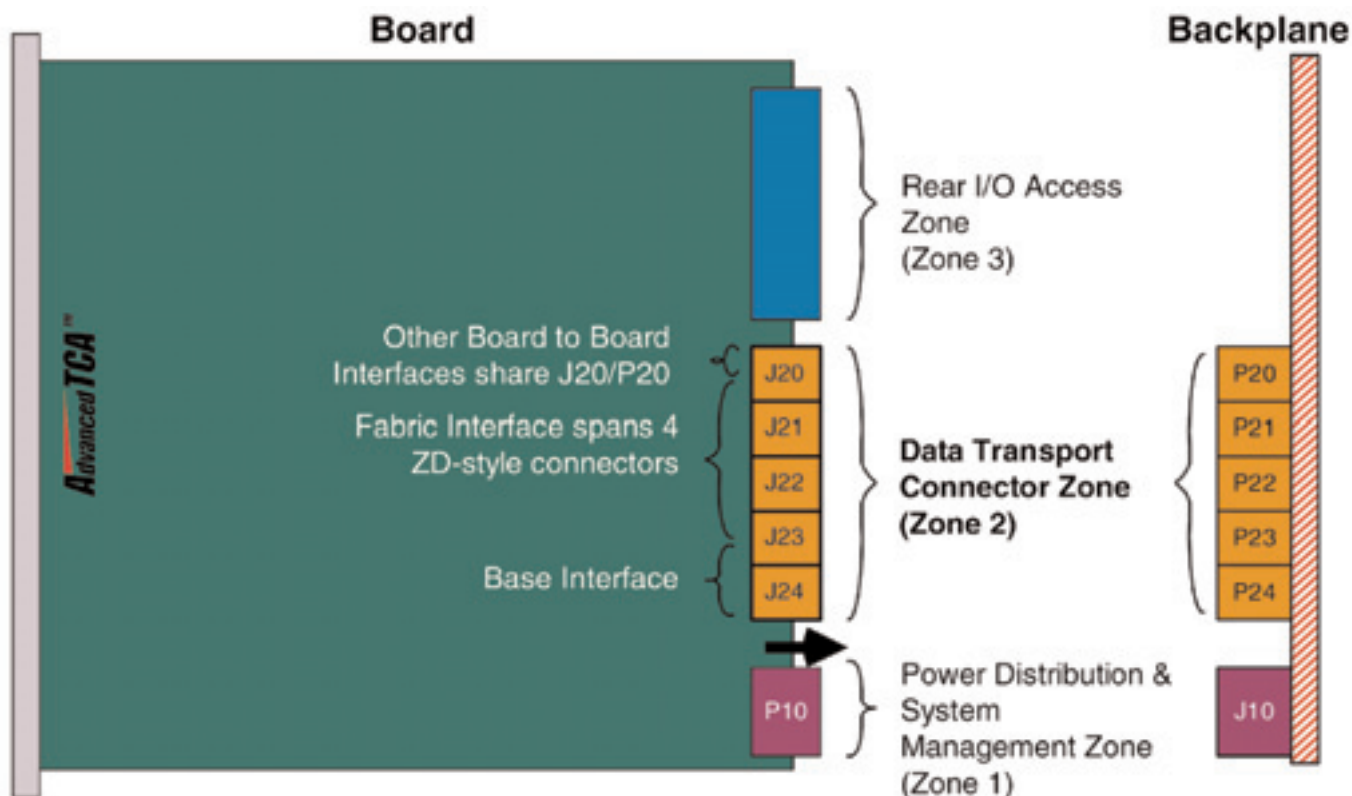

ERNI is anxious to support customers extensively and is gradually completing the product range for interconnect platforms. This also includes the ATCA (Advanced Telecom Computing Architecture) standard. This standard (also known as PICMG 3.0) is one of the latest standards addressing future telecommunication needs. ERNI can supply both power and signal connectors.

The AdvancedTCA specifications, beginning with the core specification PICMG 3.0, are aimed at further expanding the market for off-the shelf solutions for high speed communication equipment. Supplementary to the Generic PICMG 3.0 spec. the AdvancedTCA family of specifications are PICMG 3.1 for Ethernet Fabric, PICMG 3.2 for InfiniBand and PICMG 3.3 for StarFabric.

The PICMG 3.x specification family defines a single connector family for the data transfer. The electrical interconnect has to support high speed differential signaling. Key requirements are the support of various signal rates, telco-specific mechanical constraints, reliability, manufacturability, cost and availability.

Key features of the AdvancedTCA platform are:

- Scalability
- Higher data bandwidth
- High level of modularity, and configurability and remote maintainability
- Advanced system management
- Improved reliability

AdvancedTCA is a trademark of PICMG.

Zone 2 Signal Connectors

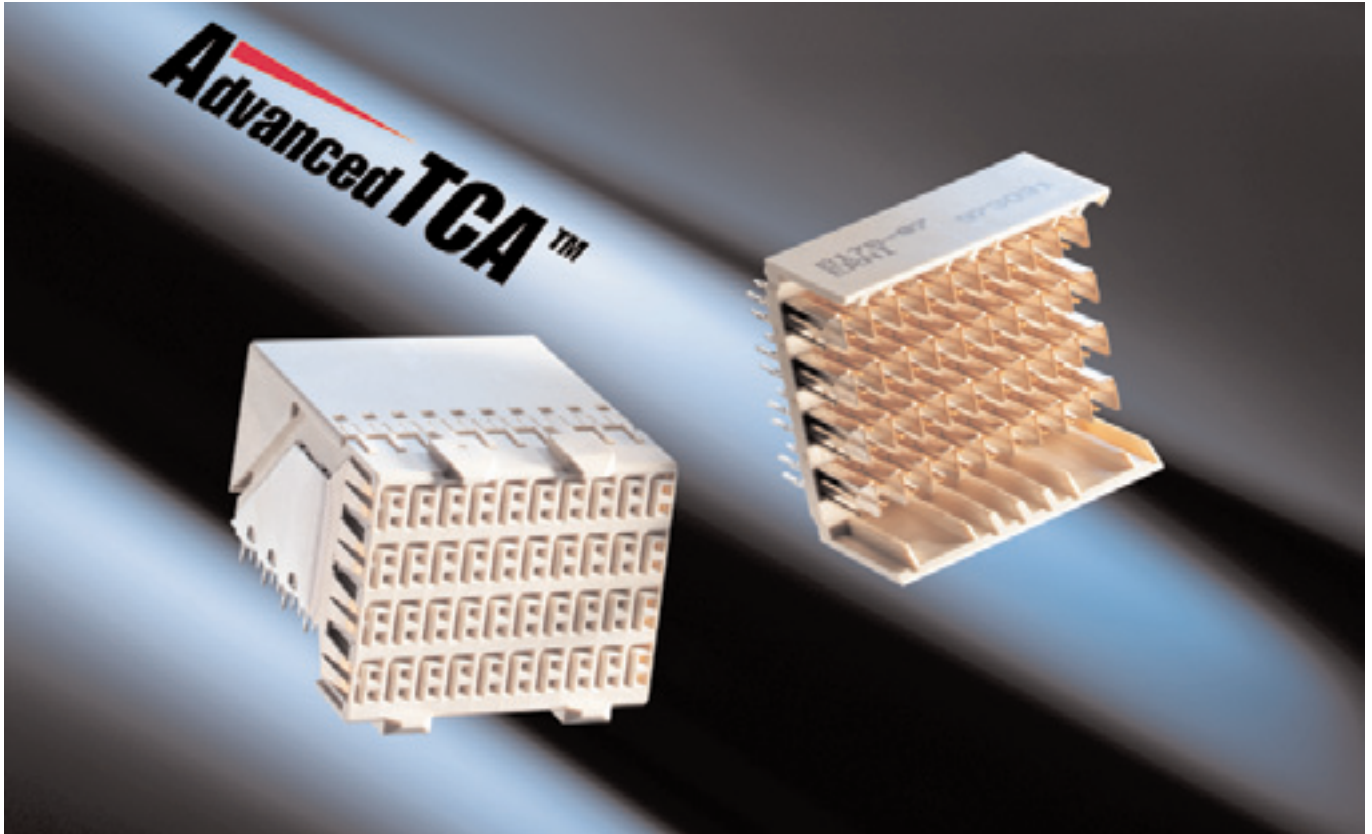

PICMG selected the ERNI ERmet ZD connector (second sourced by Tyco) for use as the high speed connector within the Data Transport Connector zone (Zone 2) with up to 5 ERmet ZD connectors. The Data Transports zone supports four different interfaces:

- Base Interface (64 signal pairs)
- Fabric Interface (120 signal pairs)
- Telephony Synchronization Clock Interface (6 signal pairs)
- Update Port Interface (10 signal pairs)

For secure and correct mating of the daughtercards ERNI provides solid alignment modules.

Ordering Information

Configuration	PCB Position	Number of Pairs	Partnumber
Backplane Connector Module 4pair	P20, P21, P22, P23, P24	40 signals / 40 grounds	973031
Daughtercard Connector Module 4pair	J20, J21, J22, J23, J24	40 signals / 40 grounds	973032

Backplane Connector Zone 2

Dimensional Drawing

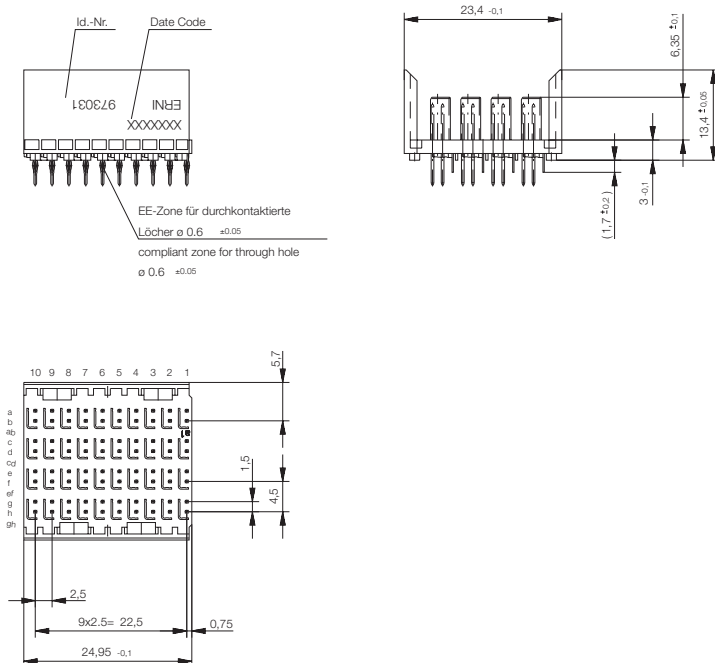

General Layout Information

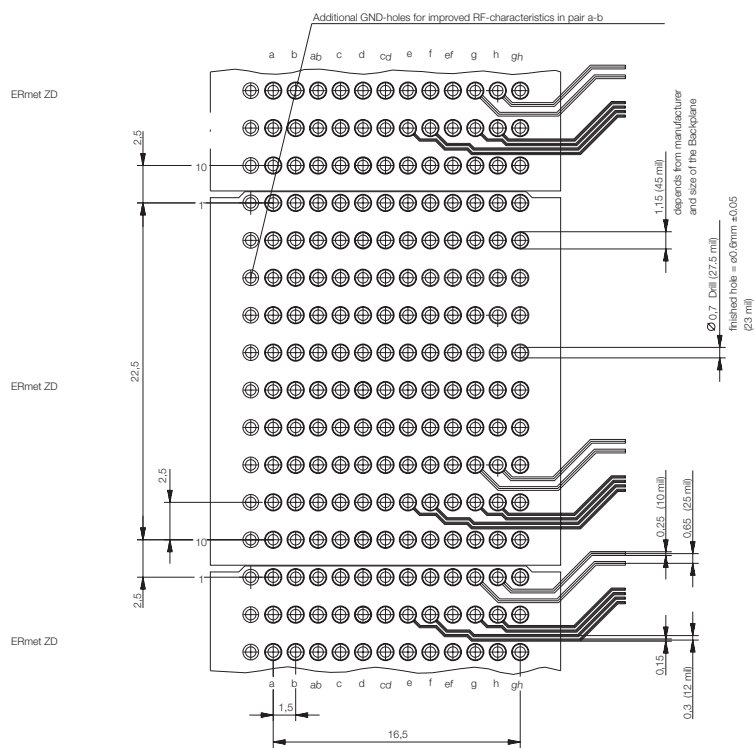

For further layout information please refer to PICMG Specifications.

Daughtercard Connector Zone 2

Dimensional Drawing

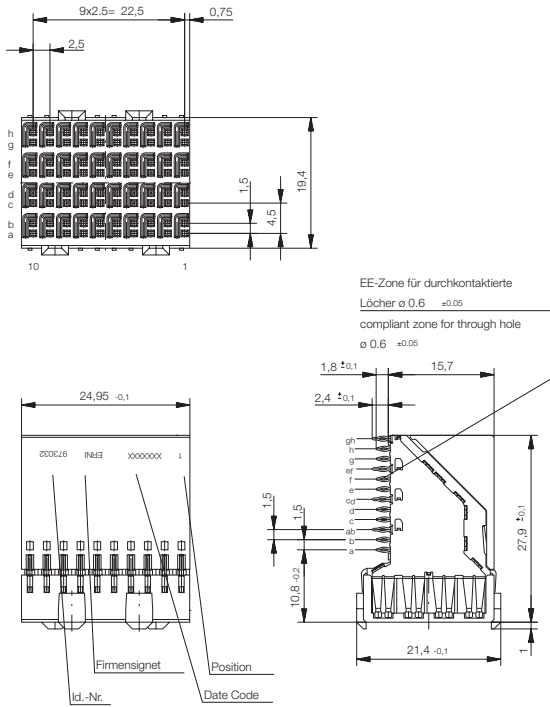

General Layout Information

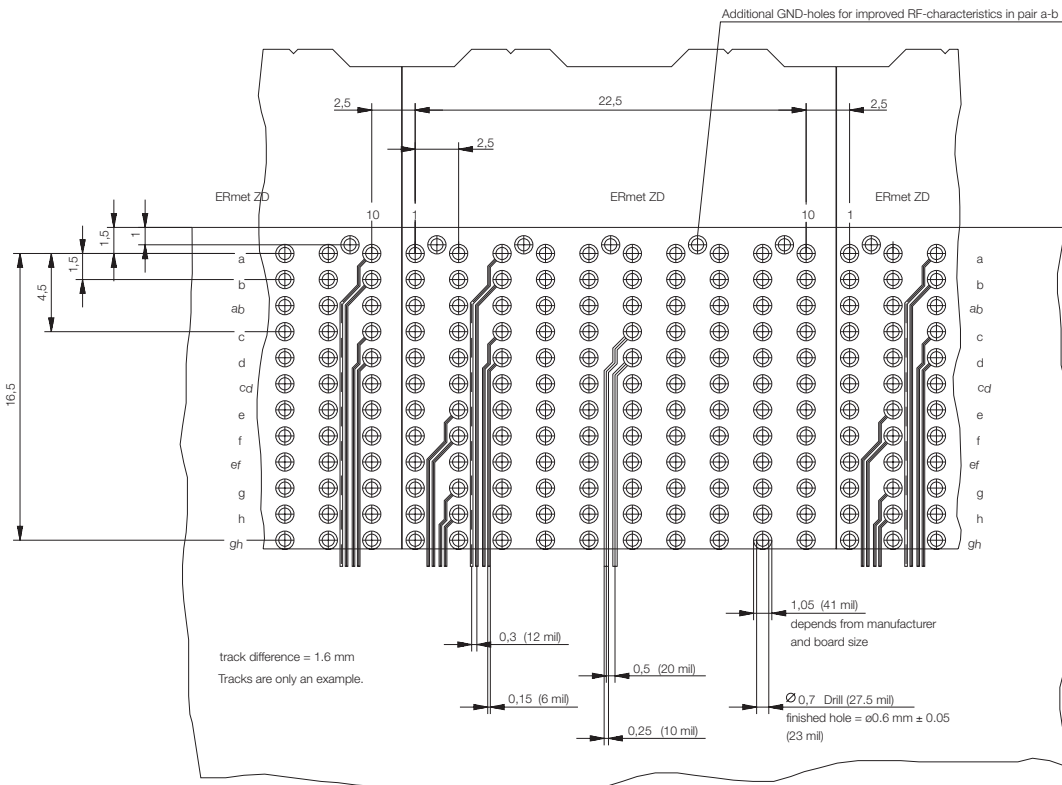

For further layout information please refer to PICMG Specifications.

Zone 1 Power Connector

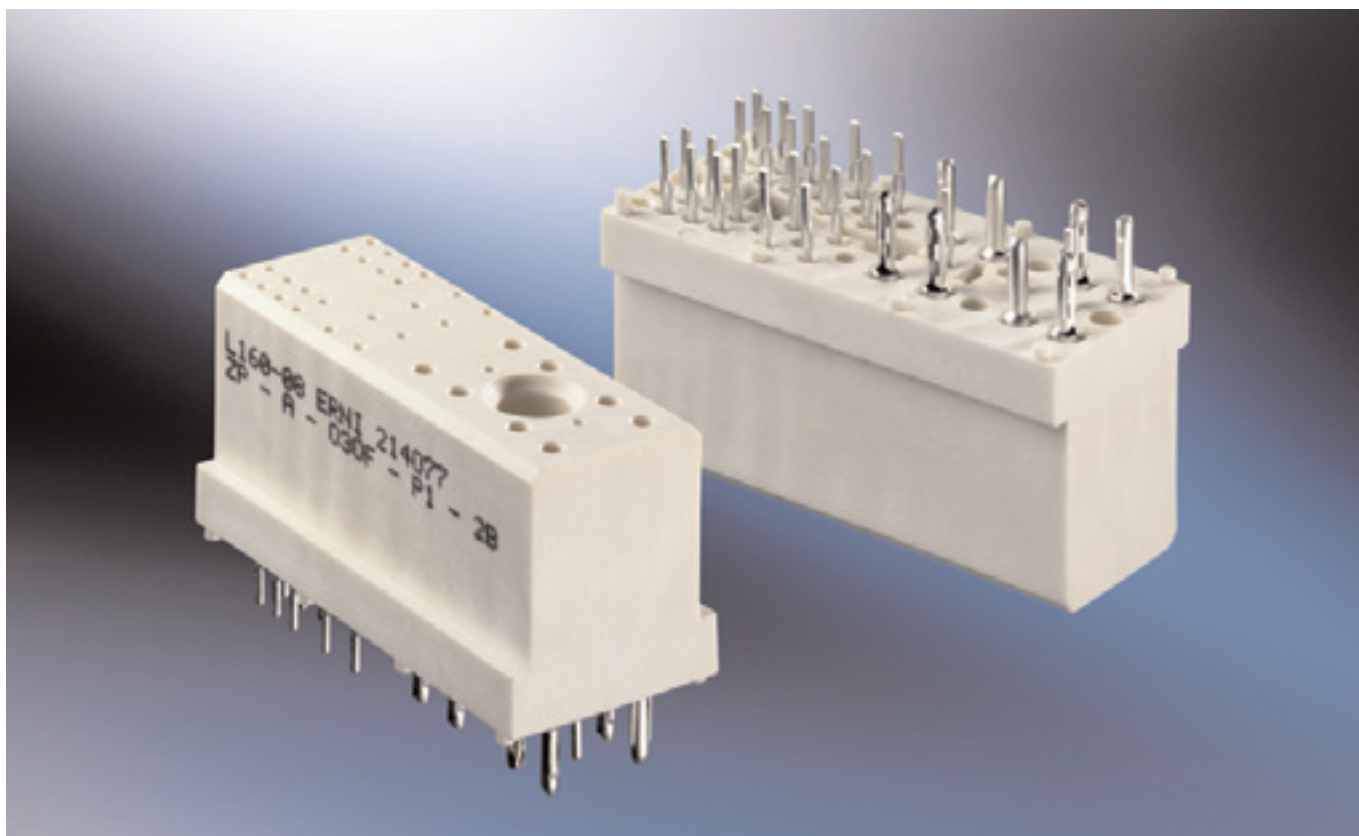

According to PICMG 3.0 the AdvancedTCA Power Connector is qualified for use in Zone 1. The connector consists of 8 size 16 contacts along with 22 size 22 contacts. The insulation body has an integrated guiding feature. The contact terminals provide compliant pressfit zones for easy assembly to the PCB. The reliability of the pressfit technology has been proven many times in long term field experiences. The pressfit zones are flat-rock compatible, there is no need for special press-in tools. The excellent design fully avoids any risk of damaging the connector during the press-in process.

The use of high conductivity copper alloy allows high current carrying capability. The power contacts are capable of carrying 16A and each signal contact is capable of carrying 2A. The female contacts' „lead in“ design combined with cavity protection prevent the contacts from being damaged.

Contacts which were plated subsequently do not have any bare ends and therefore are suitable for long term usage in critical environments. A mounting screw (customer supplied) may be used, but is not necessarily required. The connector meets all PICMG 3.0 performance requirements and is fully intermateable with alternative connectors which were designed according to the same standard.

Features

- In accordance with the PICMG 3.0 standard
- Gold over nickel plating in contact area, tin plating on pcb terminals.
- Controlled plating thickness at female mating point
- RoHS compliant
- Stamped female contacts with high conductive material for highest current carrying capacity
- Improved normal contact force and relaxation compared to machined contacts
- Reliable and proven pressfit zone
- Standard flat rock press-in tools
- No additional pcb retention hardware required
- Female contacts fully protected through proven lead-in design
- Positions 1, 2, 3 and 4 are not loaded
- For specific applications partial contact loading is possible

PICMG 3.0 Partnumber: ZP-A-030F-P1-2B
ERNI Partnumber: 214077



Electrical and Mechanical Characteristics for Zone 1 Power Connector

Technical data	
Temperature range	-55/125°C
Current rating	Pos. 5-24, 27, 32 2 A Pos. 25, 26, 28-31, 33, 34 16 A
Clearance and creepage distance	Pos. 5-16 min. 0.7 mm Pos. 17-24 min. 2.5 mm Pos. 25-26 min. 5.5 mm Pos. 27-34 min. 1.4 mm Pos. 13-16 to 17-20 min. 3.0 mm Pos. 21-24 to 25, 26 min. 4.0 mm Pos. 25, 26 to 27-29 min. 2.0 mm
Voltage rating	Has to be determined according to client-specific using case (degree of environmental pollution) according to IEC 60664.
Dielectric strength	Pos. 1-16 1000 V _{rms} Pos. 17-24 2000 V _{rms} Pos. 25-34 2000 V _{rms}
Contact resistance	< 20 mΩ
Insulation resistance	> 10 ⁴ MΩ
Materials	
Housing: Plastic material (symbol)	PA 46 GF 30
CTI value	CTI 225
UL flame rating	UL 94 V-0
UL file (plastic material)	E47960
Contact and mating area	
Base Material	Cu alloy
Plating	0.8 μm Au over 2-3 μm Ni
Termination area	
Base Material	Cu alloy
Plating	0.5-2 μm Sn matt over 2-3 μm Ni
Environment compatibility	
Recycling	no flame-retardent additives, no toxic additives allow easy recycling

Power Connector Zone 1

Dimensional Drawing

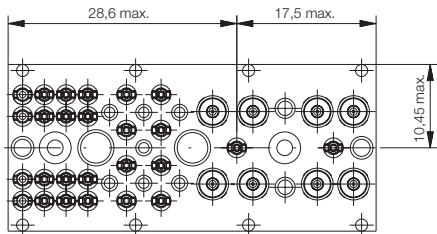

Bestückungsplan / contact assembly

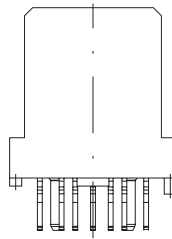
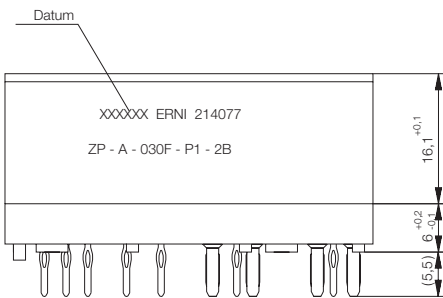
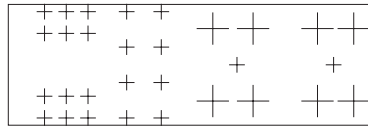

Verpackt in Tray tray packaging
Verpackungseinheit: 32 St. packaging unit 32 pcs

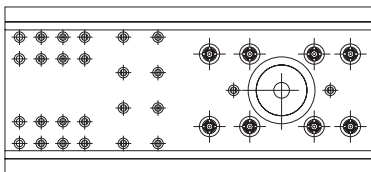
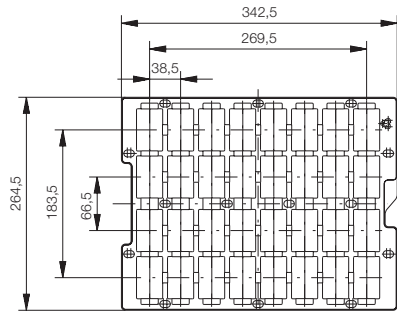

PCB Layout

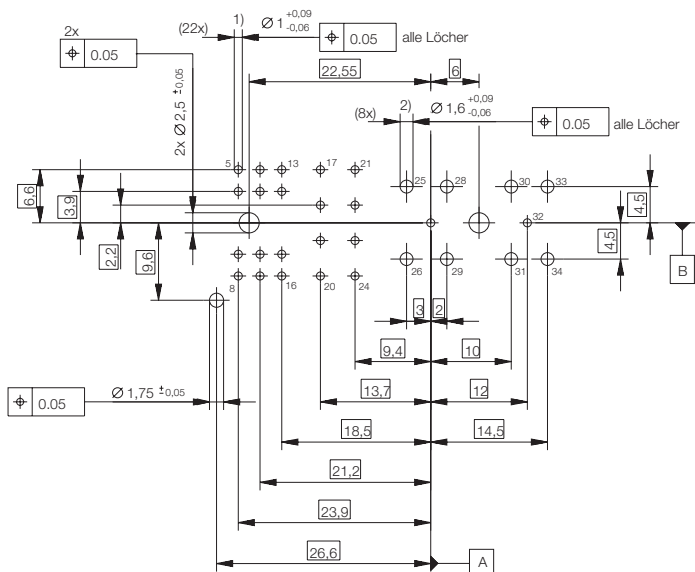

Schichtaufbau im metallisierten Loch $\phi 1$ siehe Zeichnung 164062 Nr. 6 oder 114124
diameter of drilled hole $\phi 1$ see drawing 164062 no. 6 or 114124

Schichtaufbau im metallisierten Loch $\phi 1,6$ siehe Zeichnung 164062 Nr. 10 oder 114407
diameter of drilled hole $\phi 1,6$ see drawing 164062 no. 10 or 114407

- 1) $\phi 1,0^{+0,09}_{-0,06}$ Durchmesser des metallisierten Loches
 $\phi 1,0^{+0,09}_{-0,06}$ diameter of finished plated-through hole
- 2) $\phi 1,6^{+0,09}_{-0,06}$ Durchmesser des metallisierten Loches
 $\phi 1,6^{+0,09}_{-0,06}$ diameter of finished plated-through hole

Fehlende Angaben siehe PICMG 3.0 / missing information see PICMG 3.0



ERNI Electronics GmbH

Seestrasse 9, Postfach
73099 Adelberg, Deutschland
Telefon +49 (0)71 66 50-0
Fax +49 (0)71 66 50-282
info@erni.de

Europe South America Africa

ERNI Electronics, Inc.

3005 E. Boundary Terrace
Midlothian, VA 23112 USA
Tel +1 (804) 228-4100
Fax +1 (804) 228-4099
info.usa@erni.com

North America Canada Mexico

ERNI Asia Holding Pte Ltd.

Blk 4008 Ang Mo Kio Avenue 10
#04-01/02 Techplace I
Singapore 569625
Tel +65 6 555 5885
Fax +65 6 555 5995
info@erni-asia.com

Asia

www.erni.com

ERNI Electronics GmbH 2007 • Printed in Germany.

A policy of continuous improvement is followed and the right to alter any published data without notice is reserved.